

User manual

V1.4 EN | April 2024

 **EUROBOOR**
FOR PROFESSIONALS BY PROFESSIONALS



Beveling machine

B45S



Congratulations on the purchase of your EUROBOOR B45S Beveling machine. At EUROBOOR we strive to exceed our customers' expectations by developing and providing premium and innovative portable drilling and cutting solutions. We believe that a professional like you must be able to rely on a professional supplier. Which has led us to become a major player in the industrial world, with our own factory and several offices worldwide. All because we have always listened to our customers and to the demands from the market.

Our vision is focused on developing innovative portable tools that add value for our customers and facilitate them in their daily work. We never lose sight of sustainability, time savings and cost savings.

Enjoy your new machine!

Before operating your Beveling machine, please read all instructions first. These include the Operators Manual and warning label on the unit itself. With proper use, care and maintenance your model will provide you with years of effective metal cutting performance.

TO REDUCE THE RISK OF INJURY USER MUST READ AND UNDERSTAND ALL INSTRUCTIONS

To view all our offices and their contact information please visit: www.euroboor.com

The original manual has been produced in the English language. If any discrepancies should occur in translations, reference must be made to the original version for clarification.

Table of contents

1. Safety	4
1.1 General safety instructions	4
1.2 Specific safety information	7
2. Description	10
2.1 Intended use	10
2.2 Case content.....	10
2.3 Description and features.....	11
2.4 Technical data	12
2.5 Noise and vibration information	13
2.6 Symbols	14
2.7 Environmental.....	15
3. Preparation & adjustment	16
3.1 Assembly	16
3.2 Prior to use.....	18
4. Using the machine	19
4.1 Starting and stopping	19
4.2 Working with the machine.....	21
5. Maintenance	22
5.1 Changing or replacing the milling head	24
5.2 Rotating and replacing cutting plates	25
5.3 Replacing the impeller	26
5.4 Replacing carbon brushes	27
6. Exploded view & spare part list	28
6.1 Exploded view	28
6.2 Spare part list	29
7. Troubleshooting	31
8. Warranty and service	32
9. Certification	33
9.1 CE declaration of conformity	33
9.2 Certificate of compliance: USA / Canada	34

1. Safety

1.1 General safety instructions



WARNING: *When using the bevelling machine, basic safety precautions should always be followed to reduce the risk of fire, electric shock and personal injury.*



READ AND UNDERSTAND ALL SAFETY INFORMATION AND INSTRUCTIONS.

Failure to follow the warnings and instructions may result in electric shock, fire and/or serious injury.

SAVE ALL WARNINGS AND INSTRUCTIONS FOR FUTURE REFERENCE.

The term “power tool” in the warnings refers to your mains-operated corded power tool.

Please also observe the relevant national industrial safety regulations. Non-observance of the safety instructions in the said documentation can lead to an electric shock, burns and/or severe injuries.

This Operator’s Manual including the “General Safety Instructions” should be kept for later use and enclosed with the power tool, should it be passed on or sold.

WORK AREA SAFETY

1. Keep your work area clean and well lit. Cluttered benches and dark areas increase the chance of accidents;
2. Do not operate power tools in explosive atmospheres, such as in the presence of flammable liquids, gases or dust. Power tools create sparks which may ignite the dust or fumes.
3. Keep bystanders, children, and visitors away while operating a power tool. Distractions can cause you to lose control.

ELECTRICAL SAFETY



DANGER

1. Power tool plugs must match the outlet. Never modify the plug in any way. Do not use any adapter plugs with earthed (grounded) power tools. Unmodified plugs and matching outlets will reduce risk of electric shock.
2. Avoid body contact with grounded surfaces such as pipes, radiators, ranges and refrigerators. There is an increased risk of electric shock if your body is earthed or grounded.
3. Do not expose power tools to rain or wet conditions. Water entering a power tool will increase the risk of electric shock.
4. Do not abuse the cord. Never use the cord to carry the power tool or pull the plug from an outlet. Keep cord away from heat, oil, sharp edges or moving parts. Replace damaged cords immediately. Damaged cords increase the risk of electric shock.
5. When operating a power tool outdoors, use an extension cord suitable for outdoor use. Use of a cord suitable for outdoor use reduces the risk of electric shock.
6. If operating a power tool in a damp location is unavoidable, use a residual current device (RCD) protected supply. Use of an RCD reduces the risk of electric shock.

PERSONAL SAFETY



WARNING: *Wear ear and eye protection when using this power tool.*

1. Stay alert, watch what you are doing and use common sense when using a power tool. Do not use machine while tired or under the influence of drugs, alcohol, or medication. A moment of inattention while operating power tools may result in serious personal injury.
2. Use personal protective equipment. Always wear eye protection. Protective equipment such as dust mask, non-skid safety shoes, hard hat, or hearing protection used for appropriate conditions will reduce personal injuries.
3. Prevent unintentional starting. Ensure switch is in the off-position before connecting to power source and/or battery pack, picking up or carrying tool. Carrying power tools with your finger on the switch or energising power tools that have the switch on invites accidents.
4. Remove any adjusting key or wrench before turning the power tool on. A wrench or a key that is left attached to a rotating part of the power tool may result in personal injury.
5. Do not overreach. Keep proper footing and balance at all times. This enables better control of the power tool in unexpected situations.
6. Dress properly. Do not wear loose clothing or jewellery. Keep your hair, clothing, and gloves away from moving parts. Loose clothes, jewellery, or long hair can be caught in moving parts.
7. If devices are provided for the connection of dust extraction and collection facilities, ensure these are connected and properly used.
8. Never place hands, fingers, gloves or clothing near cutting area or rotating machine parts.

POWER TOOL USE AND CARE

1. Do not force the power tool. Use the correct power tool for your application. The correct power tool will do the job better and safer at the rate for which it was designed.
2. Do not use the power tool if the switch does not turn it on or off. Any tool that cannot be controlled with the switch is dangerous and must be repaired.
3. Disconnect the plug from the power source and/or the battery pack from the power tool before making any adjustments, changing accessories, or storing power tools. Such preventive safety measures reduce the risk of starting the power tool accidentally.
4. Store power tools out of the reach of children and do not allow person unfamiliar with the power tool or these instructions to operate the power tool. Power tools are dangerous in the hands of untrained users.
5. Maintain power tools. Check for misalignment or binding of moving parts, breakage of parts, and any other condition that may affect the power tool's operation. If damaged, have the tool serviced before use. Many accidents are caused by poorly maintained tools.

6. Keep cutting tools sharp and clean. Properly maintained tools, with sharp cutting edges are less likely to bind and are easier to control.
7. Use the power tool, accessories and tool bits, etc. in accordance with these instructions, taking into account the working conditions and the work to be performed. Use of the power tool for operations different from those intended could result in a hazardous situation.
8. Use only accessories that are recommended by EUROBOOR for your power tool. Accessories that may be suitable for one machine, may become hazardous when used on another power tool.

SERVICE

1. Power tool service must be performed only by qualified repair personnel. Service or maintenance performed by unqualified personnel could result in risk of injury.
2. When servicing a power tool, use only identical replacement parts. Follow instructions in the maintenance section of this manual. Use of unauthorised parts or failure to follow maintenance instructions may create a risk of electric shock or injury.

1.2 Specific safety information

1. ELECTRICAL SAFETY



DANGER: *Electrical voltage! Risk of fatal injury due to electrical shock!*

- a) Grounded tools must be plugged into an outlet properly installed and grounded in accordance with all codes and ordinances. Never remove the grounding prong or modify the plug in any way. Do not use adaptor plugs. Check with a qualified electrician if you are in doubt whether the outlet is properly grounded. If the tools should electrically malfunction or break down, grounding provides a low resistance path to carry electricity away from the user
- b) When operation the tool outside, use an outdoor extension cord marked "W-A" or "W". These cords are rated for outdoor use and reduce the risk of electric shock
- c) Extension cables must have a sufficient cross-section so as to prevent an excessive drop in voltage, or overheating. An excessive drop in voltage reduces the output and can lead to failure of the motor
- d) Never use multiple extensions cables together. Use a single longer one instead
- e) Check the plug, cable and machine for damage each time using the machine
- f) Remove the plug from the plug socket before undertaking an maintenance work on the power tool

2. PERSONAL SAFETY

- a) Check the plug, cable and machine for damage each time using the machine
- b) Remove the plug from the plug socket before undertaking an maintenance work on the power tool



WARNING: *Risk of injury from high-temperature chips.*

- c) Never touch the tool holder and keep all vulnerable body parts clear while the machine is running, as high-temperature chips are expelled at high speed during operation
- d) During operation, always guide the machine in a direction away from the body
- e) Do not use the machine above your head



WARNING: *Risk of injury to hands.*

- f) Do not reach into the processing line with your hands
- g) Use both hands to hold and operate the machine



WARNING: *Dust created by bevelling may harm your health.*

- h) Some types of dust, such as dust from lead-based paint, is known to cause cancer, birth defects or other reproductive harm. Risk varies on exposure and should always be reduced by working in a well-ventilated area and by making use of approved safety equipment, such as dust masks specifically designed to filter out microscopic particles



WARNING: *Never machine materials which contain asbestos.*

- i) Only use recommended square carbide inserts (“cutting plates”), rated at the machine’s maximum cutting rate or higher
- j) Do not use dull or damaged cutting plates to prevent excessive friction and load, and thus to prevent damage to and failure of the machine
- k) Maintain labels and identification plates, as they carry important information. If unreadable or missing, obtain replacement

3. TOOL USE AND CARE



WARNING

- a) Hold power tool by insulated gripping surfaces, because the cutter may contact its own cord. Cutting a “live” wire may make exposed metal parts of the power tool “live” and shock the operator



WARNING

- b) Use clamps or another practical way to secure and support the workpiece to a stable platform. Holding the work by your hand or against the body leaves it unstable and may lead to loss of control.

4. RESIDUAL RISKS

In spite of the application of the relevant safety regulations and the implementation of safety devices, certain residual risks cannot be avoided.

These are:

- Impairment of hearing
- Risk of personal injury from flying particles
- Risk of burns due to accessories becoming hot during operation
- Risk of personal injury due to prolonged use.

Always try to reduce these risks as much as possible.

2. Description

2.1 Intended use

This Beveling machine is an electrically driven portable machine for machining workpieces in steel, chrome steel alloys, aluminium, aluminium alloys, brass and plastic. The machine is designed exclusively for adding bevelled edges, rounding off edges, removing burrs and removing sharp corners on workpieces. The speed of the machine is variable to suit the needs of various materials and is equipped with a graduated depth adjustable deck. It comes standard with a 45° milling head including cutting plates. Optionally available are 30° and R2.5 milling heads as well as corresponding cutting plates.



WARNING: *The machine should not be used in any other way than described in this manual. The machine should also not be converted or modified for any other form of use other than described in this manual. The user is liable for damages and accidents resulting from any modifications made or incorrect use.*

2.2 Case content

- 1 x B45S Beveling machine
- 1 x 45° milling head with cutting plates
- 1 x User manual
- 1 x Auxiliary front handle
- 1 x Spanner 22 mm
- 1 x C-spanner
- 1 x L-type torx wrench

2.3 Description and features

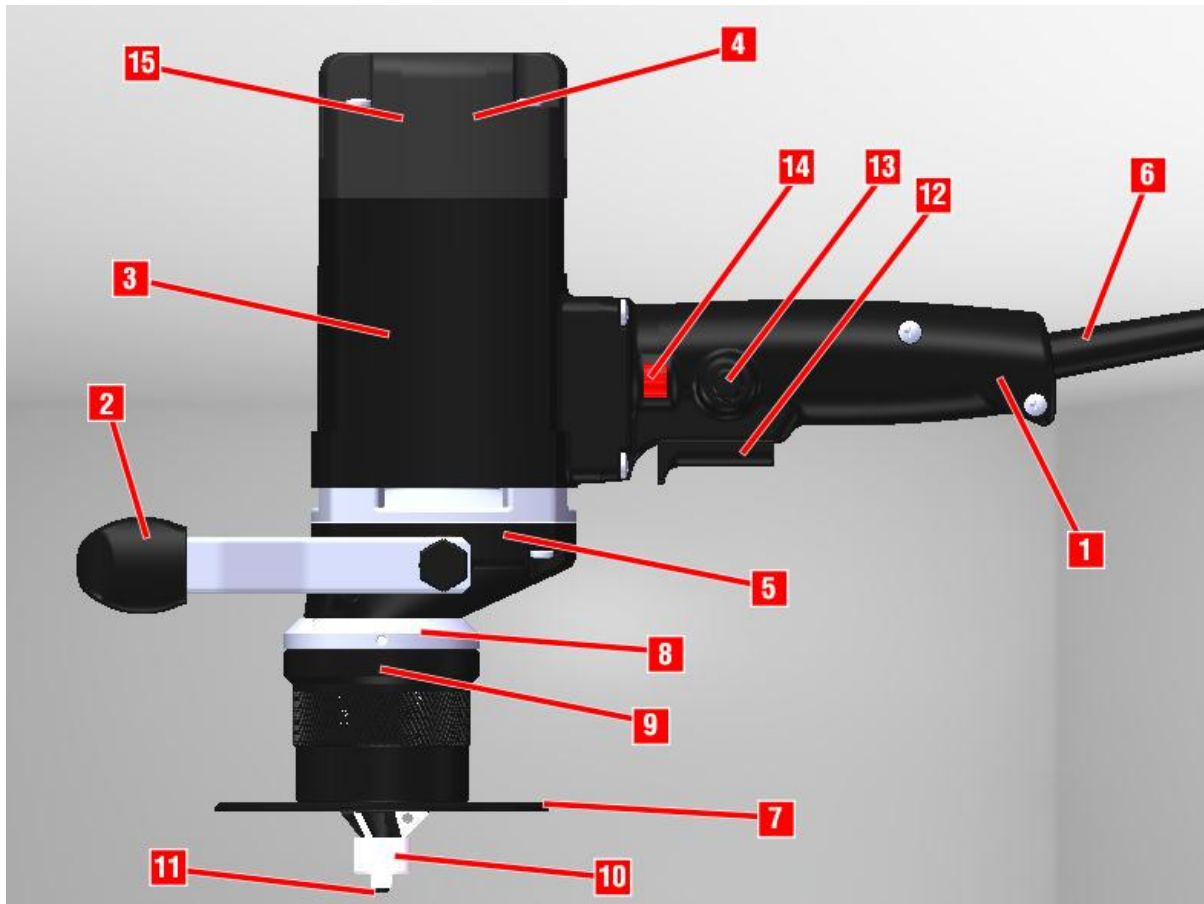

[image 1-1]

- | | |
|---------------------------------|----------------------------|
| 1. Main handle | 9. Clamping ring |
| 2. Auxiliary front handle | 10. Milling head |
| 3. Motor housing | 11. Impeller |
| 4. Motor cover | 12. On/off trigger switch |
| 5. Gear casing | 13. Lock pin |
| 6. Power cord | 14. Speed adjustment wheel |
| 7. Guiding plate / support deck | 15. Carbon brush holder |
| 8. Dial ring | |

2.4 Technical data

	Metric	Imperial
Spindle speed	1,750 – 5,250 rpm	
Max. bevel depth	6 mm (45°)	1/4" (45°)
Min. diameter for inside bevels	20 mm	13/16"
Spindle thread	M12 x 1,75	
Length	458 mm	18"
Width	137 mm	5 3/8"
Height	300 mm	11 13/16"
Weight	4.8 kg	10.6 lbs
Motor power	1250 W	11.4 A
Voltage	110 – 120 V / 60 Hz 220 – 240 V / 50 – 60 Hz	

2.5 Noise and vibration information



WARNING: *Wear hearing protection while operating the Beveling machine*

2.5.1 Noise

L_{pA} : 86.47dB(A)

L_{wA} : 97.47dB(A)

Uncertainty K: 3dB(A)

The declared vibration total value has been measured in accordance with a standard test method and may be used for comparing one tool with another. The declared vibration total value may also be used in a preliminary assessment of exposure.

2.5.2 Vibration

Main Handle: 2.738m/s²

Auxiliary handle: 2.572m/s²







Uncertainty K: 1.5m/s²



WARNING: *The vibration emission during actual use of the Beveling machine can differ from the declared total value depending on the ways in which the machine is used.*

There is the need to identify safety measures to protect the user that are based on an estimation of exposure in the actual conditions of use (taking into account all parts of the operating cycle such as the times when the tool is switched off and when it is running idle in addition to the trigger time).

2.6 Symbols

Symbol	Term, meaning	Explanation
	Read documentation	Be absolutely sure to read the documentation in this user manual and specifically the "General safety instructions" and "Specific safety information".
	Wear ear protection	Use ear protection during operation.
	Wear eye protection	Use eye protection during operation.
	Danger/warning/caution	Read and apply the information in the adjacent text!
	European conformity symbol	Confirms the conformity of the beveling machine with the directives of the European Community.
	Class of protection II	Product with double insulation and exposed (touchable) conductive parts additionally connected to the protective earth conductor.
mm	Millimeter	Unit of measurement for length, width, height or depth.
kg	Kilogram	Unit of measurement for the mass.
V	Volt	Unit of measurement for the electric voltage.
A	Ampere	Unit of measurement for the electric current intensity.
W	Watt	Unit of measurement for the output.
rpm	Revolutions per minute	Unit of measurement for the revolutions.
No load	No load speed	Revolution speed at no load.

2.7 Environmental



Separate collection. This product must not be disposed of with normal household waste.



Separate collection of used products and packaging allows materials to be recycled and used again. Re-use of recycled materials helps prevent environmental pollution and reduces the demand for raw materials.

Local regulations may provide for separate collection of electrical products from the household, at municipal waste sites or by the retailer when you purchase a new product.

3. Preparation & adjustment

3.1 Assembly



WARNING: To reduce the risk of injury, turn machine off and disconnect from power source before installing and removing accessories, before adjusting or changing set-ups or when making repairs. An accidental start-up can cause injury.

Setting bevel depth at zero position

The machine's bevel depth is set and delivered at position zero. If the setting is disturbed, the zero position has to be set again.

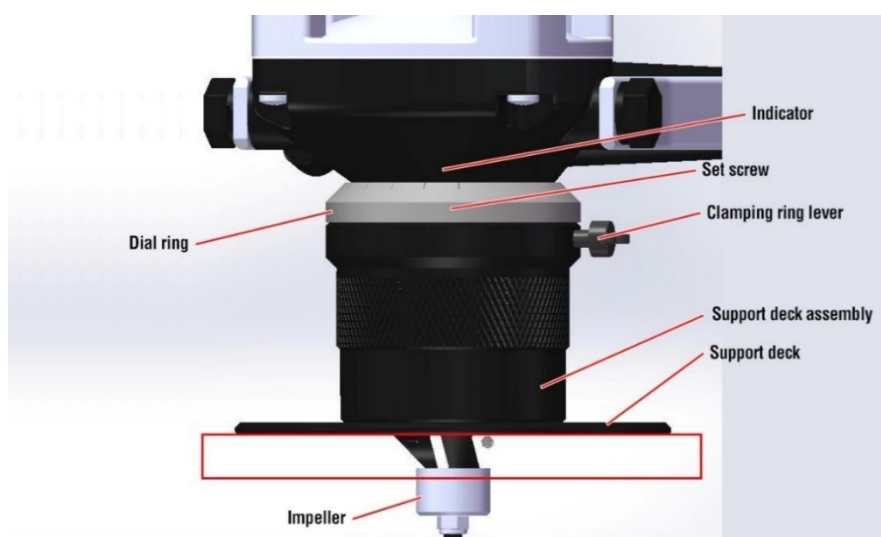

[image 2-1]

1. Loosen the clamping ring lever.
2. Loosen the support deck assembly until the inserts are below flush level. Keep a steel ruler square on both the impeller and the support deck.
3. Slowly adjust the support deck until it touches the cutting plate. This is the zero position.
4. Lock the clamping ring lever.
5. Untighten the set screw in the dial ring.
6. Rotate the dial ring until the zero matches the indicator on the machine.
7. Retighten the set screw in the dial ring.

Setting bevel depth

1. Loosen the clamping ring lever.
2. Rotate the entire support deck assembly, use the dial ring as indication for the depth adjustment. Each complete rotation corresponds to a bevel depth of 1.5 mm (1/16"), this is indicated on the scale.

The bevel depth (in mm) is calculated as follows, with example:

$$\begin{array}{rccccccc} [value\ on\ scale] & + & [value\ on\ dial\ ring] & = & bevel\ depth \\ 1.5 & + & 0.7 & = & 2.2\ mm \end{array}$$

3. Tighten the clamping ring lever.

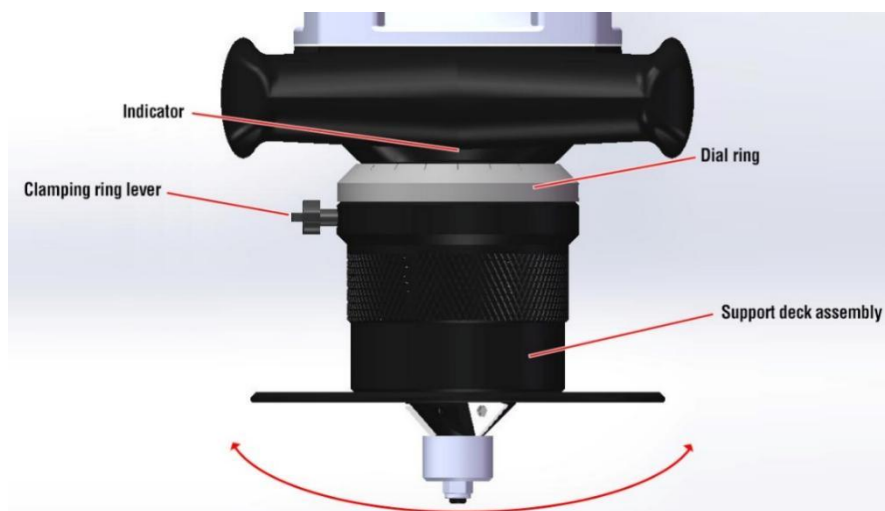

[image 2-2]

3.2 Prior to use

Check the machine for possible damage; Before using the machine, carefully check the protective components or slightly damaged components to ensure they are operating perfectly and as intended.

Check that moving parts are in perfect working order, do not jam and check whether the parts are damaged. All parts must be correctly installed and fulfill all conditions necessary to ensure perfect operation of the machine.

Damaged protective components must be repaired or replaced according to specifications by EUROBOOR or any authorized EUROBOOR dealer.

DO NOT use under wet conditions or in presence of flammable liquids or gases.

DO NOT let children come into contact with the machine. Supervision is required when inexperienced operators use this machine.



WARNING:

- Make sure the machine is always in a stable position before and during use.
- Do not operate the machine above your head.
- Never touch the milling head while the machine is running.
- Always operate the machine away from your body.
- Work is performed with two-hand operation for all machine positions. When operation the machine ensure that the machine is held with both hands in such a way that both hands are kept away from the processing point. Make sure the auxiliary front handle is positioned correctly.
- Do not use this tool continuously for a period over 30 minutes.

Electrical safety

Always check that the power supply corresponds to the voltage on the rating plate. If the supply cord is damaged, it must be replaced by a specially prepared cord available at EUROBOOR or your EUROBOOR dealer.

4. Using the machine



WARNING: Always observe the safety instructions and applicable regulations.



WARNING: To reduce the risk of serious personal injury, turn the machine off and disconnect the machine from power source before making any adjustments or removing/installing attachments or accessories.

4.1 Starting and stopping



WARNING: Make sure the power circuit voltage is the same as shown on the specification plate on the machine. Make sure the On/Off trigger switch is in the "Off" position before plugging in the machine.

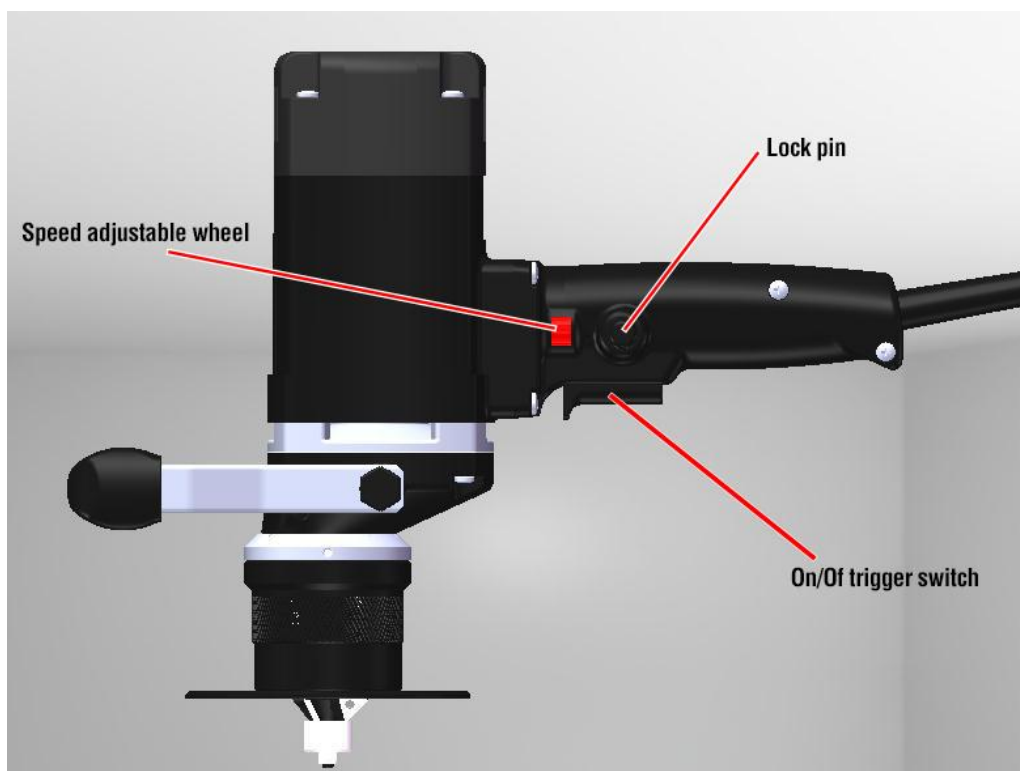

[image 3-1]

Switching on

Press the On/Off trigger switch to start the machine. The anti-kickback and breakthrough torque control provides a “slow start”: the machine needs a couple of seconds to reach its set running speed. The On/Off trigger switch can be locked in the “on” position by pressing the lock pin while the machine is running.

Controlling running speed

This machine is equipped with variable speed control. The speed adjustment wheel can be rolled down to increase the machine speed and up to decrease the machine speed.

Switching off

If the lock pin is not engaged, release the On/Off trigger switch. If the lock pin is engaged, squeeze and release the On/Off trigger switch.



WARNING: *The milling head of the machine needs a couple of seconds to come to a complete standstill after the machine has been switched off. Be careful for any chips that may be released by the rotation and make sure that nothing touches the moving parts.*

Overheat protection

This machine is equipped with an overheat protection which switches off the motor when running hot. Allow the machine at least 5 minutes to cool off and let it run idle for another couple of minutes before resuming work.

4.2 Working with the machine

- 1) Set the speed adjustment wheel to the highest speed.
- 2) Switch the machine on. Do not move the machine towards the workpiece until full speed has been reached.
- 3) Hold the machine in such a way that the support deck is flat on the workpiece.
- 4) Slightly push the machine against the workpiece and let the machine do its work. Lower the speed of the machine if necessary (depending on the material of the workpiece) and slowly move the machine in the correct direction to make the bevel. Avoid collisions during processing.



WARNING: *From the users' perspective, the milling head is spinning clockwise. The machine must always be guided from left to right (conventional up milling), or clockwise when processing inside bevels.*

- 5) Once the bevelling pass is completed, take the machine from the workpiece.



WARNING: *Do not bevel more than 2 mm depth per pass. If more depth is needed, adjust the bevelling depth in steps of maximum 2 mm and make multiple passes until the required depth is reached.*

- 6) Switch the machine off.

Note: *adding cutting oil will improve operation and increase the life span of the cutting plates.*

5. Maintenance

Your EUROBOOR beveling machine has been designed to operate over a long period of time. Continuous satisfactory operation depends upon proper tool care and regular cleaning.



CAUTION: *To reduce the risk of injury, turn the machine off and disconnect machine from power source before installing and removing accessories, before adjusting or changing set-ups or when making repairs. Be sure the switch is in the OFF position. An accidental start-up can cause injury.*

Just as every beveling machine with moving parts, your EUROBOOR beveling machine also needs regular maintenance service. A few recommendations follow :

Visually check the machine for damage

The machine must be checked before operating for any signs of damage that will affect the operation of the machine. Particular notice must be taken of the main cable, if the machine appears to be damaged it should not be used. Failure to do so may cause injury or death.

Worn bearings in the milling head and blunt cutting plates are the main cause for uneven finishes and rough and long operation. Replace worn components in good time to reduce stress on the machine and increase its longevity.

Only use original EUROBOOR parts, accessories and consumables. Have maintenance carried out by an EUROBOOR specialist.

Cleaning

- Clean all dirt, dust and metal of your beveling machine;
- Blow dirt and dust out all air passages with dry air as often as dirt is seen collecting in and around the air vents. Wear approved eye protection and an approved dust mask;
- Never use solvents or other harsh chemicals for cleaning the non-metallic parts of the tool. These chemicals may weaken the materials used in these parts. Use a cloth dampened only with water and mild soap. Never let any liquid get inside the tool; never immerse any part of the tool into a liquid.

Check machine grease

The gearbox grease should be checked and replaced at least once a year, or every 100 hours of operation, to ensure maximum lubrication and cooling, and thus the best performance of the machine.

5.1 Changing or replacing the milling head

The Beveling machine is standard equipped with a 45° milling head. When showing signs of wear, a replacement piece (part number B45.1011) can be ordered from your EUROBOOR reseller.

For every type of milling head the replacement procedure is the same.

1. Loosen the clamping ring lever.
2. Rotate the entire support deck assembly until it comes off the machine.
3. Use the supplied spanner 22 mm to hold the spindle in place.
4. Use the supplied C-spanner to loosen the milling head, and turn it off the machine.

Assembly in reversed order. Always check for damaged or worn-out parts and replace them when necessary. Always clean and lubricate parts prior to refitting.

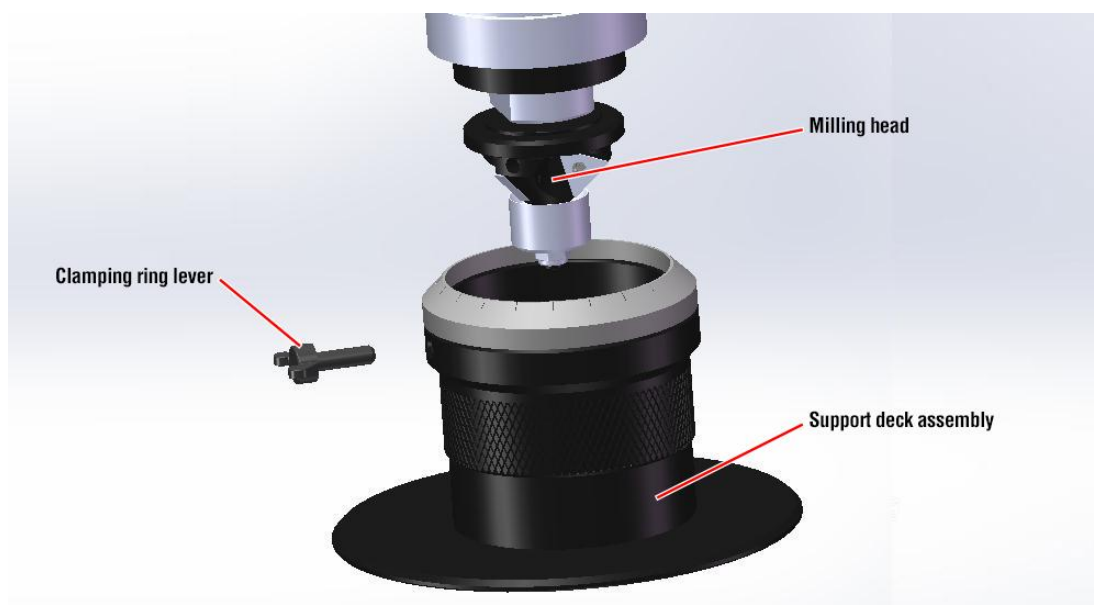

[image 4-1]

5.2 Rotating and replacing cutting plates

Each of the 3 cutting plates on the milling head have 3 usable sides. When the used side of either of the 3 cutting plates is dull, the cutting plates can be rotated to position a sharp side in the correct direction.

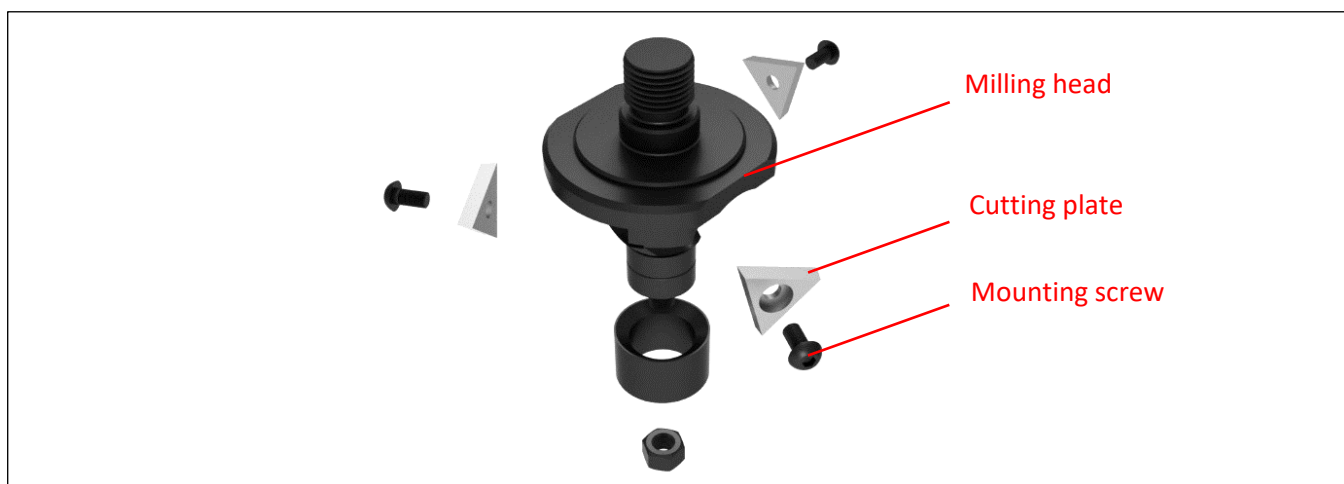

[image 4-2]

Rotating cutting plates:

1. Remove the milling head as described in previous paragraph: Changing or replacing the milling head.
2. Clamp the milling head in a vice on the far outer rim.
3. Mark dull side on all 3 cutting plates.
4. Undo mounting screw with the supplied L-type Torx wrench.
5. Take of cutting plate, rotate 120° and put it back in place.
6. Fasten the mounting screw with the supplied L-type Torx wrench.
7. Refit the milling head and other components as described in previous paragraph: Changing or replacing the milling head.



WARNING: Always rotate the 3 cutting plates at the same time.



WARNING: Always replace the 3 cutting plates at the same time, using the same brand and type for all 3 pieces.

Once all 3 sides of the cutting plates are used, they need to be replaced. Use official EUROBOOR cutting plates to ensure the same quality and endurance.

Replacing cutting plates:

1. Undo mounting screw with the supplied L-type Torx wrench.
2. Take of old cutting plate, put replacement piece in place.
3. Fasten the mounting screw with the supplied L-type Torx wrench.

5.3 Replacing the impeller

The impeller contains 2 bearings which are subject to regular wear. A worn-out impeller results in a roughly operating machine and an uneven bevel. It can be replaced as follows:

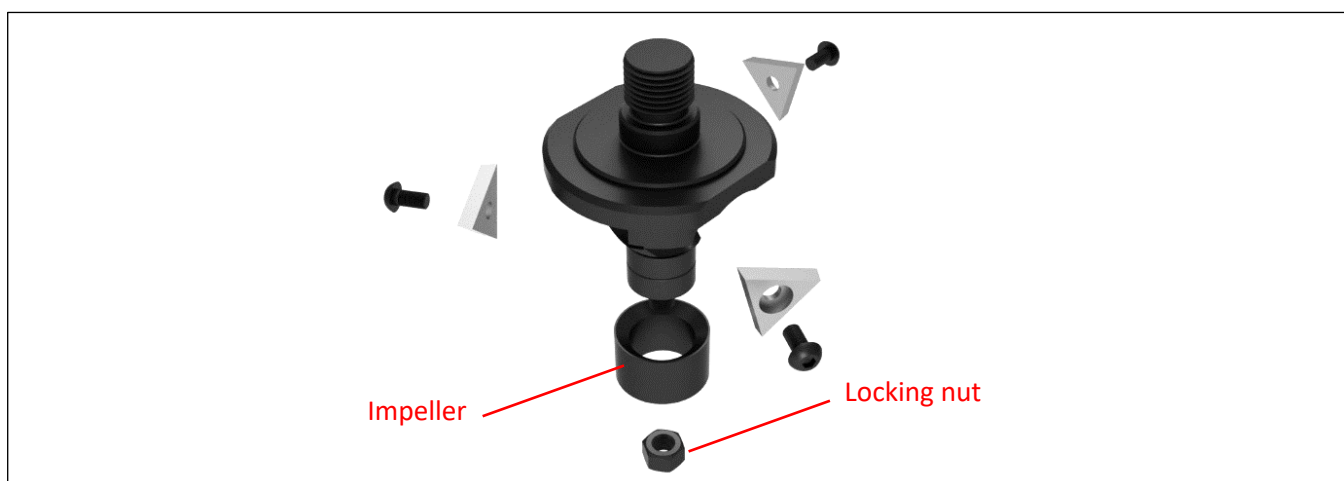

[image 4-3]

1. Remove the milling head as described in paragraph: Changing or replacing the milling head.
2. Clamp the milling head in a vice on the far outer rim.
3. Undo the locking nut.
4. Use a small pulley puller to pull the impeller with its bearings off the milling head.
5. Gently tap the new impeller with bearings into place.
6. Replace the locking nut and fasten it.
7. Refit the milling head and other components as described in paragraph: Changing or replacing the milling head.

5.4 Replacing carbon brushes

Carbon brushes are normal wearing parts and may need replacement after a longer time of use. The motor of the machine comes to a standstill whenever the brushes are worn out. To prevent sudden standstill during operation, replacing the carbon brushes when they reach their wear limit is advised.

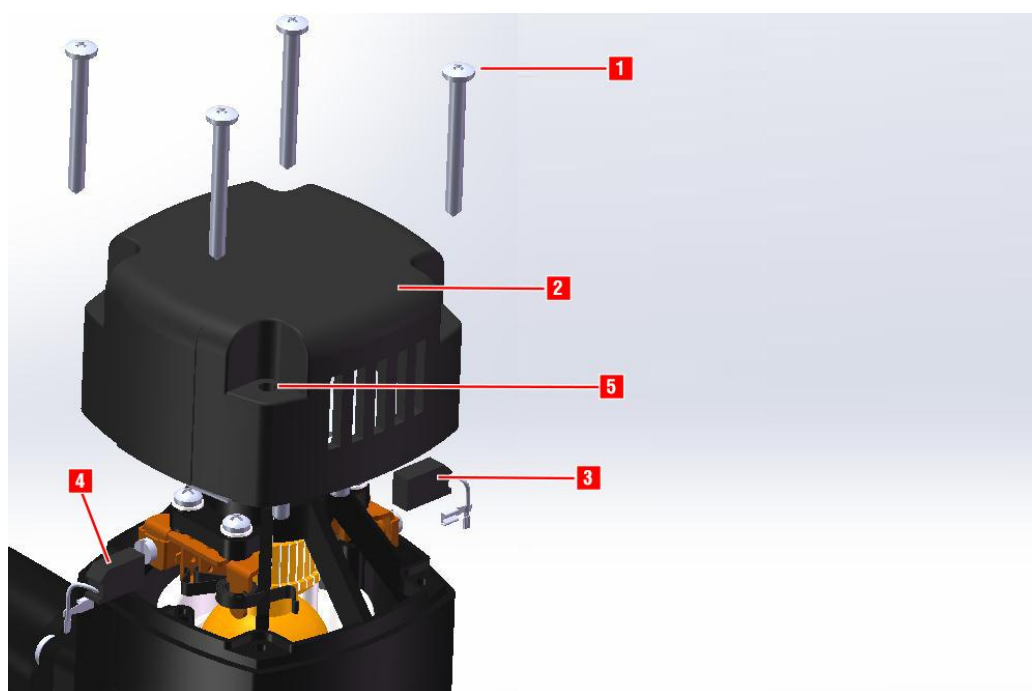

[image 4-4]

1. Unscrew the 4 screws from the top cover.
2. Take of the top cover.
3. Withdraw the old carbon brushes.
4. Place the new carbon brushes in the destined slots, ensuring they align properly and slide freely.
5. Place back the top cover and screw in all four screws.



WARNING: Always replace carbon brushes as a pair. Always use official EUROBOOR carbon brushes which can be ordered from your EUROBOOR reseller.

6. Exploded view & spare part list

6.1 Exploded view

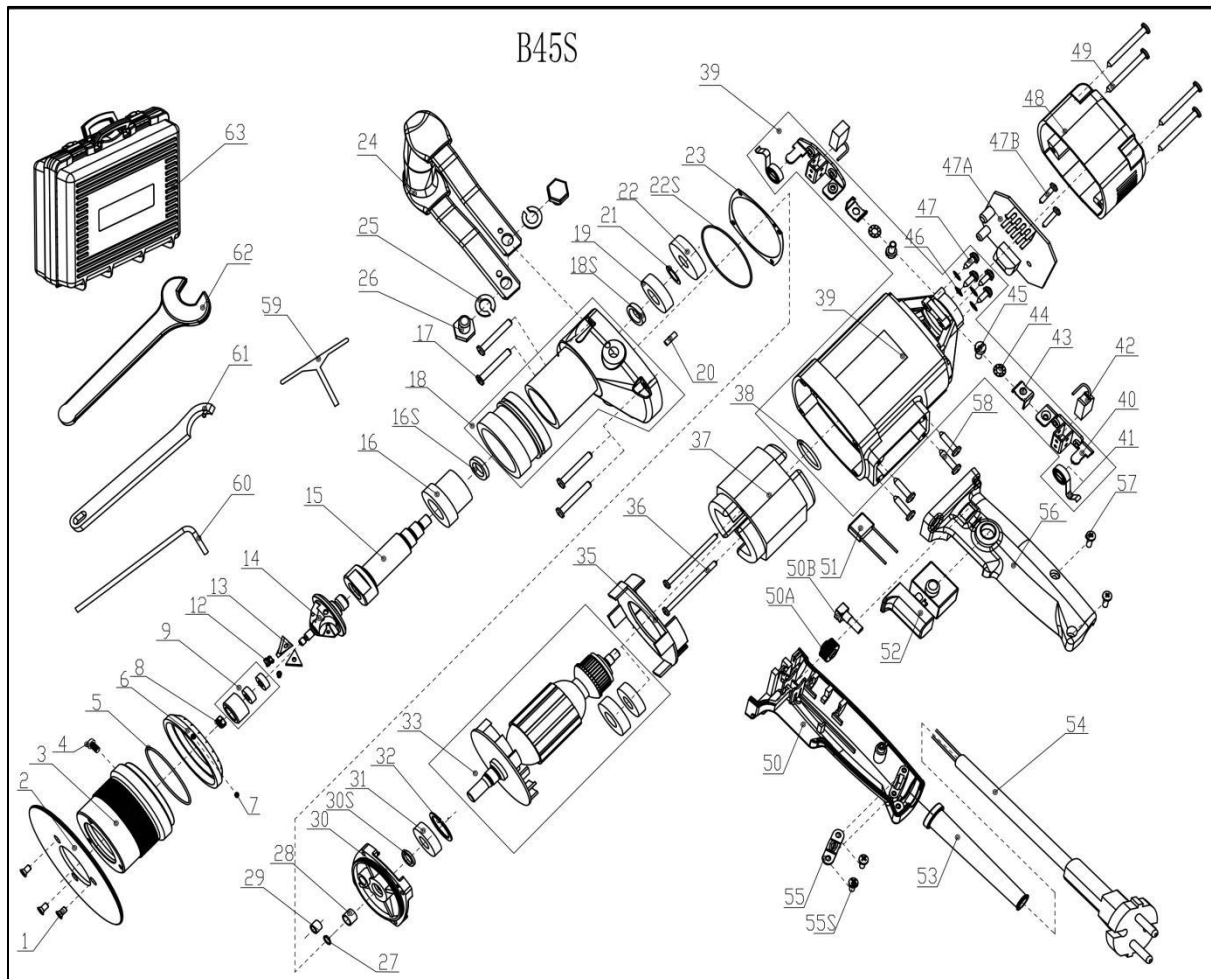

6.2 Spare part list

No.	Part number	Description	Qty
1	B45S.0003	Screw M4 x 8	3
2	B45S.0004.SET	Guide plate Set	1
3	B45S.0008	Connection sleeve	1
4	B45S.0016	Butterfly bolt M5 x 16	1
5	B45S.0006	O ring	1
6	B45S.0010	Dial ring	1
7	B45S.0136	Set screw M3 x 4	1
8	B45S.0001	Locknut M5	1
9	B45S.1012	Bush / nut set B45S	1
10	B45S.0002	Guide wheel 45°	1
	B45S.0002A	Guide wheel 30°	1
11	B45S.0126	Iron seal bearing	2
12	B45S.0017	Fixing screw Torx M3 x 6	3
13	LKS.20	Cutting plate 30°/45°	3
	LKS.20-R	Cutting plate R2.5	3
14	B45S.0019	Milling head 45°	1
	B45S.0019A	Milling head 30°	1
	B45S.0019B	Milling head R2.5	1
15	B45S.0014	Output shaft	1
16	B45S.0015	Combined bearing	1
16S	B45S.0013	Wool felt ring	1
17	B45S.0101	Screw M5 x 35	4
18	B45S.0036	Gearbox inc. Scale set	1
18S	B45S.0011	Oil bearing 20 x 28 x 6	1
19	B45S.0196	Sealed bearing 6002 DDU	1
20	032.0211	Casing pin 4 x 12	1
21	040.0181	Adapter ring	1
22	B45S.0186	Gear	1
22S	050.0071	O-ring 82 x 1.8	1
23	050.0207	Gasket middle	1
24	B45S.0315X	Handle	1
25	B45S.0106C	Spring washer	2
26	B45S.0106A	Screw M10 x 16	2
27	100.0571	Circlip 471 11 x 1	1
28	B45S.0020	Armature seal	1
29	040.0161	Needle bearing HK0810	1
30	B45S.0236X	Gear box cover	1
30S	050.0064	Oil bearing 15 x 21 x 3	1
31	050.9070	Bearing 6001V V	1
32	032.0166	Circlip 472/28/1.2	1
33	B45S.0032	Armature 220V	1
	B45S.0032A	Armature 110V	1

No.	Part number	Description	Qty
34	032.0126	Bearing 608ZZ 8 x 22 x 7	1
34S	050T.0180	Ring magnet	1
35	050.0261	Baffle	1
36	020.0024	Screw M4 x 60	2
37	B45S.0151	Field 220V	1
	B45S.0151A	Field 110V	1
38-41 + 43-47	050.0142	Housing	1
42	050.0147	Carbon brush set 220V	1
	050.0148	Carbon brush set 110V	1
47A	050T.0333	Speed control unit 220V	1
	050T.0334	Speed control unit 110V	1
47B	050T.0332	Screw for speed control unit	2
48	050.0111	End cover	1
49	050.0106	Screw 4.8 x 45	4
50	B45S.0027	Handle part right	1
50A	B45S.0035	Speed adjustment wheel	1
50B	100.4572	Speed potentiometer 100 K	1
51	B45S.B035	Capacitance unit	1
52	B45S.0023	Switch	1
53	B45S.0024	Main cable protection sleeve	1
54	020.0036	Main cable EU 220V	1
	020.0036/USA	Main cable USA 110V	1
	020.0036/UK 110-16A	Main cable UK 110V	1
	020.0036/AU	Main cable AU 220V	1
	020.0036/UK	Main cable UK 220V	1
55	B45S.0026	Press plate	1
55S	055.0022A	Screw M4 x 12	2
56	B45S.0021	Handle part left	1
57	032.0116	Screw M4 x 16	2
58	B45S.0012	Screw M5 x 20	4
59	B45S.0039	Wrench S4	1
60	B45S.0030	Wrench T10	1
61	B45S.0029	Cutter wrench 34/36	1
62	B45S.0028	Single open-end wrench 22	1
63	B45S.0106X	Machine case	1

7. Troubleshooting

Problem	Cause
The motor does not work	<ul style="list-style-type: none"> • Damaged or defective wiring • Carbon brushes are stuck or worn out • Defective On / Off switch • Defective control unit • Defective armature and/or field
Motor running roughly and/or seizing up	<ul style="list-style-type: none"> • Bent spindle • Shaft extending from the motor is bent
Motor humming, big sparks and motor has no force	<ul style="list-style-type: none"> • Armature damaged (burned) • Field burned • Carbon brushes worn out
Overheating	<ul style="list-style-type: none"> • Blocked motor housing vents • Forcing tool to work too fast
Tool does not bevel effectively	<ul style="list-style-type: none"> • Accessory may be damaged, worn or tool is used on the wrong type of material.

If any problem that you are having with your EUROBOOR B45S cannot be solved using this troubleshooting guide, please refer to your EUROBOOR distributor.

8. Warranty and service

Warranty

EUROBOOR B.V. warrants this bevelling machine to be free of material defects and workmanship errors under normal use for a period of 12 months after date of purchase. This 12 month period can be extended to 24 months in total by registering the product on our website: <https://EUROBOOR.com/support/register/>

Serial number:	<input type="text"/>
Date of purchase:	<input type="text" value="/ /"/>

Service

To maximize the lifetime of your EUROBOOR bevelling machine always use service and parts from an official EUROBOOR distribution channel. Whenever in need of such, always contact original point of sales or if no longer existent the distributor of EUROBOOR products in your country.

9. Certification

9.1 CE declaration of conformity

EUROBOOR BV declares that the following appliance complies with the appropriate basic safety and health requirements of the EC guidelines based on its design and type, as brought into circulation by EUROBOOR BV.

<i>Designation/function</i>	Bevelling Machine
<i>Brand</i>	EUROBOOR
<i>Types</i>	B45S
<i>Ratings and principal</i>	220 - 230V AC, 50-60Hz, Class II
<i>Characteristics</i>	Power 1,150W Speed 1,750 – 5,250 rpm (no load)
<i>Used standards</i>	EN 55014-1:2017 EN IEC 61000-3-2:2019, EN 61000-3-3:2013+A1:2019 IEC 62841-1: 2014, COR1:2014, COR2:2015
<i>Report numbers:</i>	4789544699-1 / 4789275120.1.1-04 / 4789275120.2.1-04
<i>Testing laboratory</i>	UL-CCIC Company limited

Zoetermeer, 04 February 2022

Albert Koster



Managing Director

9.2 Certificate of compliance: USA / Canada

9.2.1 USA

Certificate No.	UL-US-2142036-0
Certificate Holder:	EUROBOOR B.V. Kryptonstraat 110, 2718 TD Zoetermeer, Netherlands
Certified Product:	Class II Bevelling Machine
Model Designation:	B45, B45S
Fulfilled Standards:	UL 62841-1, 1st Ed., Issue Date: 2015-02-20, Revision Date: 2020-08-21 The standard(s) listed here reflect the status at the time of the release of this certificate.
Date of Issue:	08-09-2021
Certificate Type:	UL US Mark

USA standard conformity certificate

The Certificate is based on a valid, applicable U.S. national standard in combination with all the related services such as regular factory inspections. The UL test mark is proof of compliance with U.S. national standards. It shows the buyer, customer, local authority having jurisdiction or consumer that a device has been successfully tested and certified by an impartial and independent testing laboratory. The principle of integrating regular spot checks into an approval, assures both the client and the buyer of continued compliance. This system guarantees the quality of the test-mark and therefore represents a credible marketing tool.

9.2.2 Canada

Certificate No.	UL-CA-2135276-0
Certificate Holder:	EUROBOOR B.V. Kryptonstraat 110, 2718 TD Zoetermeer, Netherlands
Certified Product:	Class II Bevelling Machine
Model Designation:	B45, B45S
Fulfilled Standards:	CAN/CSA C22.2 NO. 62841-2-1, 1st Ed., Issue Date: 2018-04-30 The standard(s) listed here reflect the status at the time of the release of this certificate.
Date of Issue:	08-09-2021
Certificate Type:	UL CA Mark

Approval for the Canadian Market

This accredited test mark, referred to as the UL mark, serves as proof of compliance with the Canadian national standards set by the Standards Council of Canada (SCC).

Provincial Regulators across Canada recognize the UL mark as proof of product compliance to mandatory Canadian regulatory and code requirements. Retail buyers accept it on products they're sourcing.

Consumers recognize it on products they purchase as a symbol of safety..

Certified products may be labeled with a test mark.