

ECO.40s+/M

Magnetic drilling machine

EUROBOOR

FOR PROFESSIONALS BY PROFESSIONALS

Technical data

	Metric	Imperial
Annular cutting	Ø 12 - 40 mm	Ø 7/16" - 1 9/16"
Twist drilling	Ø 1 - 16 mm	Ø 1/16" - 5/8"
Countersinking	Ø 10 - 45 mm	Ø 3/8" - 1 3/4"
Length	264 mm	10 3/8"
Width	180 mm	7 1/16"
Height	367 - 447 mm	14 7/16" - 17 5/8"
Stroke	145 mm	5 11/16"
Weight	12.2 kg	26.9 lbs
Magnet (l x w x h)	168 x 84 x 49 mm	6 5/8" x 3 5/16" x 1 15/16"
Magnetic force	1,850 kg	4,079 lbs
Motor power	1,150 W	10.5 A
Total power	1,200 W	10.9 A
Speed (no load)	600 rpm	
Speed (load 1,150 W, 10.5 A)	380 rpm	
Spindle (Weldon)	19.05 mm	3/4"
Voltage	110 - 120 V / 60 Hz	
	220 - 240 V / 50 - 60 Hz	

* Without power cord and handles

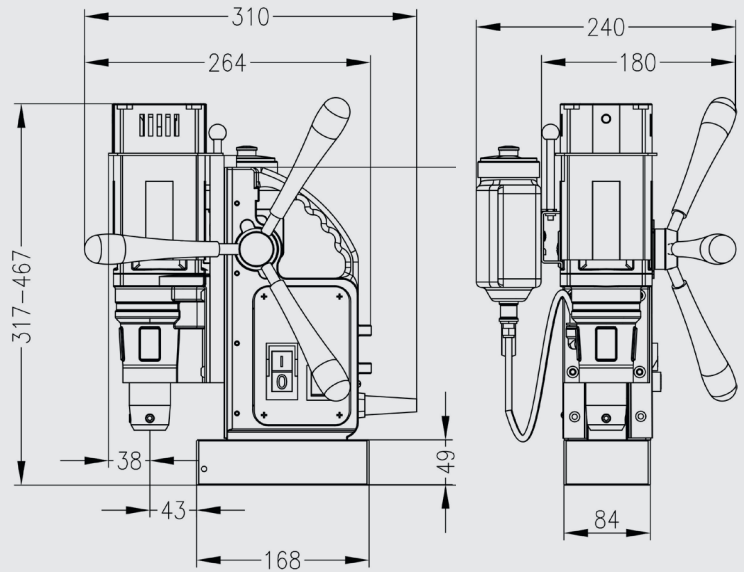

Features



Power surge protection



Power fluctuation protection



Gyro-Tec



Integrated motor cable



Automatic shut-off



Oil lubricated gearbox



Carbon brush wear indicator



Magnet LED-indicator (SensorTec)

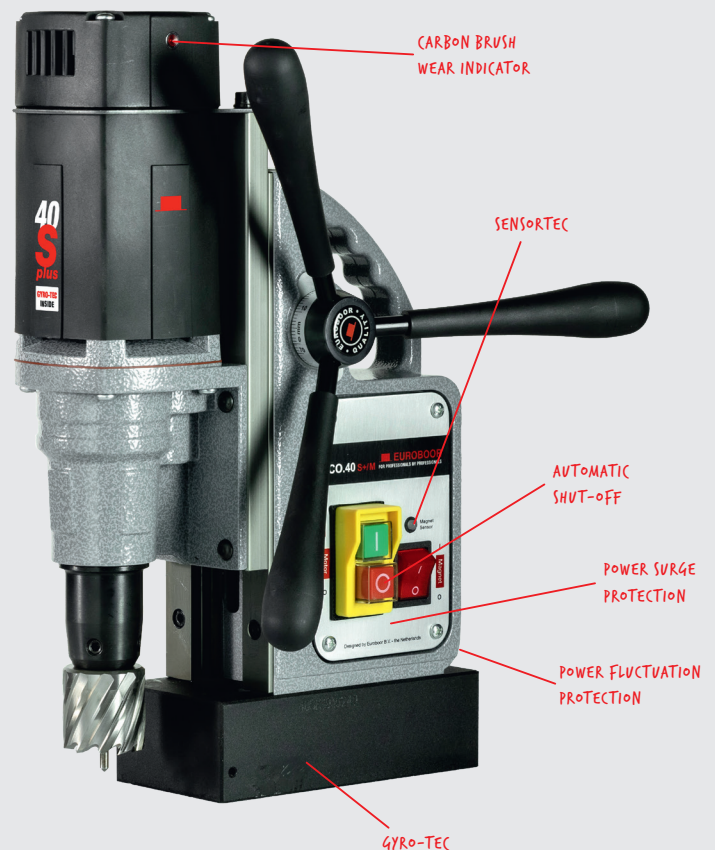

Euroboor makes every effort to meet quality and integrity requirements. That is why we as an organization are proud of the recognition of some leading organizations worldwide:



www.euroboor.com