

# ECO.32-T

## Magnetbohrmaschine

**EUROBOOR**

FOR PROFESSIONALS BY PROFESSIONALS

### Technische Daten

	Metrisch	Kaiserlich
Kernbohrer	Ø 12 - 32 mm	Ø 1/2" - 1 1/4"
Spiralbohrer	Ø 1 - 13 mm	Ø 1/16" - 1/2"
Kegelsenker	Ø 10 - 40 mm	Ø 3/8" - 1 9/16"
Gewindeschneiden	Ø M3 - M12	Ø 1/8" - 1/2"
<hr/>		
Länge	320 mm	12 5/8"
Breite	210 mm	8 1/4"
Höhe	370 - 512 mm	14 9/16" - 20 3/16"
<hr/>		
Hub	150 mm	5 15/16"
Gewicht*	11 kg	24,3 lbs
Magnet (l x b x h)	160 x 80 x 42 mm	6 5/16" x 3 1/8" x 1 5/8"
Magnetstärke	1.500 kg	3.305 lbs
Motorleistung	1.000 W	9,1 A
Totale Kraft	1.050 W	9,5 A
Drehzahl (Leerlauf)	150 - 600 U/Min <sup>1</sup>	
Drehzahl (belastet 1.000 W, 9,1 A)	225 U/Min <sup>1</sup>	
Spindel (Weldon)	19,05 mm	3/4"
Netzspannung	110 - 120 V / 60 Hz 220 - 240 V / 50 - 60 Hz	

\* Ohne Netzkabel und Griffe

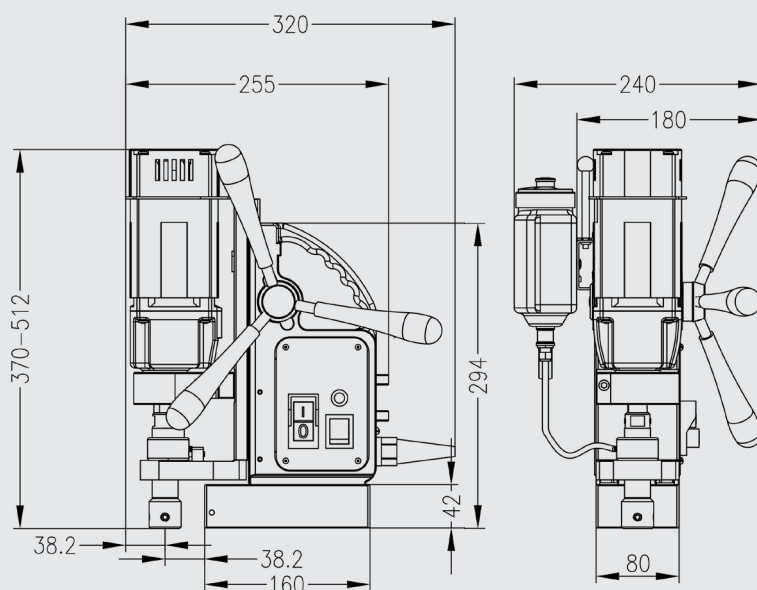

### Eigenschaften



Einstellbare  
Drehzahl



R/L-Rotation



LED-Magnet-  
Anzeige  
(SensorTec)



Gewinde-  
schneiden



Euroboor unternimmt alle Anstrengungen, um die Qualitäts- und Integritätsanforderungen zu erfüllen. Deshalb sind wir als Organisation stolz auf die Anerkennung einiger führender Organisationen weltweit:



[www.euroboor.com](http://www.euroboor.com)