

ECO.32-T

Taladro de base magnética

EUROBOOR

FOR PROFESSIONALS BY PROFESSIONALS

Datos técnicos

	Métrico	Imperial
Corte anular	Ø 12 - 32 mm	Ø 1/2" - 1 1/4"
Brocas helicoidal	Ø 1 - 13 mm	Ø 1/16" - 1/2"
Avellanador	Ø 10 - 40 mm	Ø 3/8" - 1 9/16"
Roscado	Ø M3 - M12	Ø 1/8" - 1/2"
<hr/>		
Longitud	320 mm	12 5/8"
Ancho	210 mm	8 1/4"
Altura	370 - 512 mm	14 9/16" - 20 3/16"
<hr/>		
Trazo	150 mm	5 15/16"
Peso*	11 kg	24,3 lbs
Imán (l x a x a)	160 x 80 x 42 mm	6 5/16" x 3 1/8" x 1 5/8"
Fuerza magnética	1.500 kg	3.305 lbs
Potencia del motor	1.000 W	9,1 A
Potencia total	1.050 W	9,5 A
Velocidad (sin carga)	100 - 600 rpm	
Velocidad (carga 1.000 W, 9,1 A)	225 rpm	
Husillo (Weldon)	19,05 mm	3/4"
Voltaje	110 - 120 V / 60 Hz 220 - 240 V / 50 - 60 Hz	

* Cable de alimentación y asas exclusivos

Características



Velocidad ajustável



Rotación R / L



Indicador LED de imán (SensorTec)



Roscado

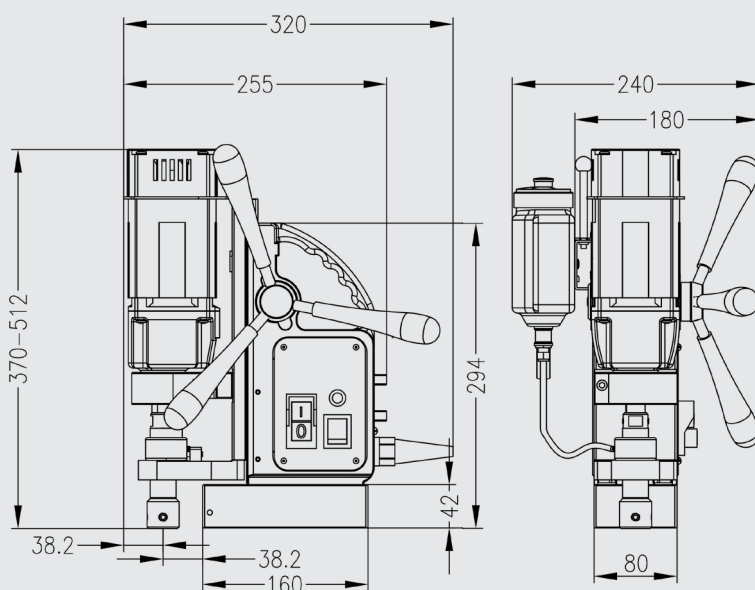

Euroboor hace todo lo posible para cumplir con los requisitos de calidad e integridad. Es por eso que nosotros, como organización, estamos orgullosos del reconocimiento de algunas organizaciones líderes en todo el mundo:



114

www.euroboor.com