

# ECO.100s+/TD

## Perceuse magnétiques

**EUROBOOR**

FOR PROFESSIONALS BY PROFESSIONALS

### Données techniques

	Métrique	Impérial
Coupe annulaire	Ø 12 - 100 mm	Ø 1/2" - 4 3/4"
Forage hélicoïdal	Ø 1 - 31,75 mm	Ø 1/16" - 1 1/4"
Fraisage	Ø 10 - 105 mm	Ø 3/8" - 4 1/8"
Taraudage	M3 - M30	Ø 1/8" - 1 3/16"
Longueur	365 mm	14 3/8"
Largeur	310 mm	12 3/16"
Hauteur	515 - 715 mm	20 1/4" - 28 1/8"
Longueur de course	260 mm	10 1/4"
Poids*	31 kg	68,3 lbs
Aimant (l x l x h)	220 x 110 x 64 mm	8 11/16" x 4 5/16" x 2 1/2"
Base Vac	3.000 kg	6.615 lbs
Puissance moteur	1.900 W	17,3 A
Puissance totale	2.050 W	18,6 A
Vitesse (à vide)		(I) 42 - 110 tpm (II) 65 - 190 tpm (III) 140 - 400 tpm (IV) 220 - 620 tpm
Vitesse (sous charge 1.900 W, 17,3 A)		(I) 85 tpm (II) 152 tpm (III) 270 tpm (IV) 480 tpm
Broche (Weldon)	MT3 31,75 mm	MT3 1 1/4"
Source d'alimentation	110 - 120 V / 60 Hz 220 - 240 V / 50 - 60 Hz	

\* Sans cordon d'alimentation ni poignées

### Caractéristiques



Vitesse réglable



Torque control



Rotation gauche/droite



Protection contre la surchauffe



Protection contre les surtensions



Protection contre les fluctuations de puissance



Gyro-Tec



Arrêt automatique



Smart Restart



Boîte de vitesse lubrifiée à l'huile



Indicateur d'usure des balais de charbon



Aimant biphasé (TempTec)



Indicateur LED force magnétique (SensorTec)



Aimant à base pivotante



Taraudage

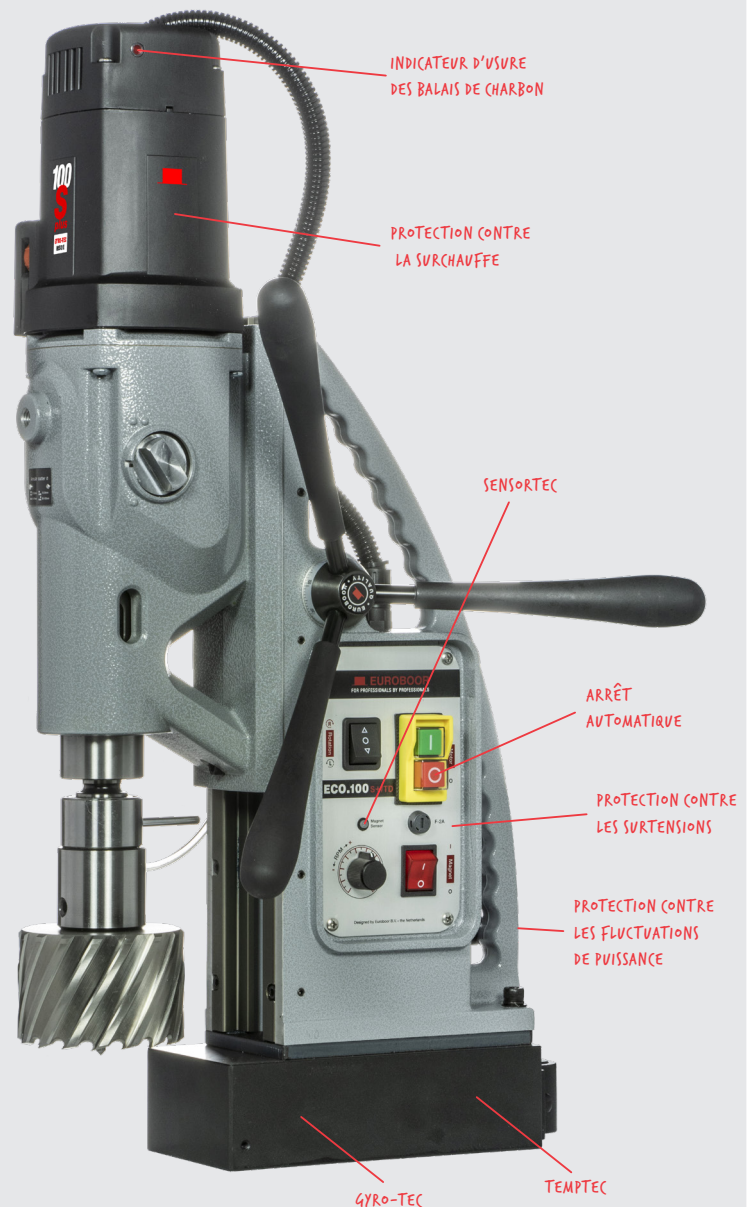
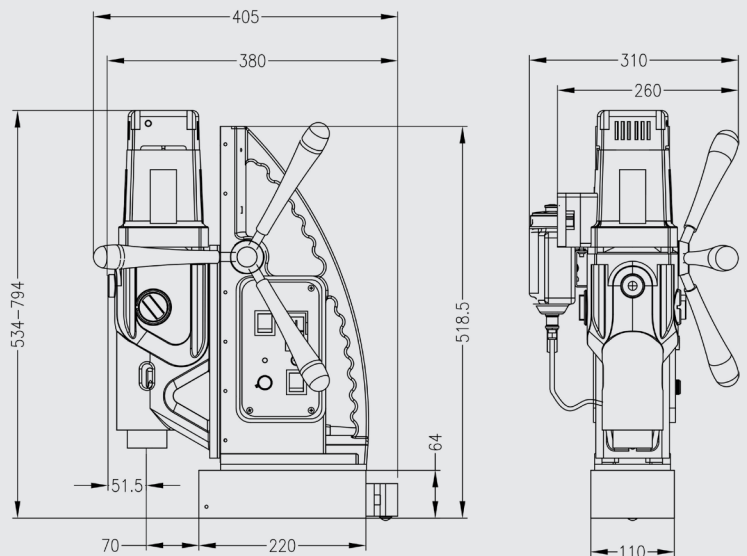

Euroboor travaille d'arrache-pied pour répondre aux exigences de qualité et d'intégrité. C'est pourquoi nous, en tant que la Sté. Euroboor, sommes fiers de la reconnaissance que plusieurs organisations de premier plan mondial nous ont donné:



www.euroboor.com