

EBM.36+ / P-18V

Furadeira de base magnética sem fio

EUROBOOR

FOR PROFESSIONALS BY PROFESSIONALS

Dados técnicos

	Métrico	Imperial
Corte anular	Ø 12 - 36 mm	Ø 7/16" - 1 7/16"
Perfuração helicoidal	Ø 1 - 13 mm	Ø 1/16" - 1/2"
Escareamento	Ø 10 - 40 mm	Ø 3/8" - 1 9/16"
Comprimento	325 mm	12 13/16"
Largura	235 mm	9 1/4"
Altura	370 - 410 mm	14 9/16" - 16 1/8"
Curso	140 mm	5 1/2"
Peso (Incluindo bat.)*	10,2 kg	22,4 lbs
Ímã (l x l x a)	157 x 85 x 45 mm	6 3/16" x 3 3/8" x 1 3/4"
Força magnética	650 kg	1.433 lbs
Espessura mínima do material	6 mm	1/4"
Potência do motor	1.000 W	
Potência total	1.000 W	
Velocidade (sem carga)		530 rpm
Velocidade (cargat)		430 rpm
Eixo (Weldon)	19,05 mm	3/4"
Capacidade da bateria	18 V 5 Ah Li-ion, 18 V 9 Ah Li-ion	

* Alças exclusivas

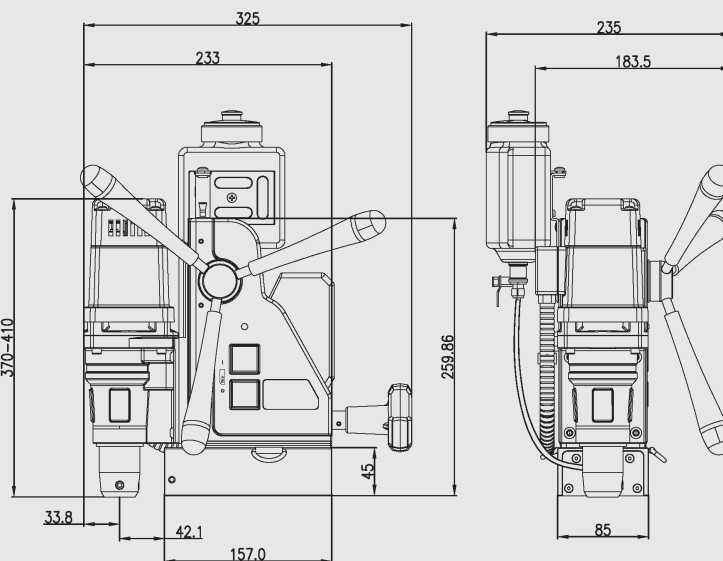

Características



Proteção contra sobrecarga



Proteção contra superaquecimento



Gyro-Tec



Cabo de motor integrado



Ímã permanente



Motor sem escovas



Indicador magnético de LED (SensorTec)



Operada à bateria



Plataforma Makita-LXT-18V

Acessórios



Baterias de 5Ah 18V
EB.18V-5A



Baterias de 9Ah 18V
EB.18V-9A



Carregador
EBC1



A Euroboor faz todos os esforços para atender aos requisitos de qualidade e integridade. É por isso que nós, como organização, temos orgulho do reconhecimento de algumas organizações líderes em todo o mundo:



www.euroboor.com