

TUBE.30s+

Perceuse magnétiques

EUROBOOR

FOR PROFESSIONALS BY PROFESSIONALS

Données techniques

	Métrique	Impérial
Coupe annulaire	Ø 12 - 30 mm	Ø 1/2" - 1 3/16"
Forage hélicoïdal	Ø 1 - 13 mm	Ø 1/16" - 1/2"
Fraisage	Ø 10 - 35 mm	Ø 3/8" - 1 3/8"
Longueur	275 mm	10 13/16"
Largeur	185 mm	7 1/4"
Hauteur	326 - 416 mm	12 13/16" - 16 3/8"
Longueur de course	90 mm	3 9/16"
Poids*	10,3 kg	22,7 lbs
Aimant (l x l x h)	187 x 165 x 83 mm	7 3/8" x 6 1/2" x 3 1/4"
Base Vac	532 kg	1.175 lbs
Diamètre minimal du tuyau	3 mm	1/8"
Epaisseur minimale de la matière	76,2 mm	3"
Puissance moteur	900 W	8,2 A
Puissance totale	950 W	8,6 A
Vitesse (à vide)		775 tpm
Vitesse (sous charge 900 W, 8,2 A)		400 tpm
Broche (Weldon)	19,05 mm	3/4"
Source d'alimentation		110 - 120 V / 60 Hz 220 - 240 V / 50-60 Hz

* Sans cordon d'alimentation ni poignées

Caractéristiques



Protection contre les surtensions



Protection contre les fluctuations de puissance



Gyro-Tec



Arrêt automatique



Boîte de vitesse lubrifiée à l'huile



Indicateur d'usure des balais de charbon



Surface extérieure ronde

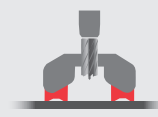

Surface plan



Surface intérieure ronde

Euroboor travaille d'arrache-pied pour répondre aux exigences de qualité et d'intégrité. C'est pourquoi nous, en tant que la Sté. Euroboor, sommes fiers de la reconnaissance que plusieurs organisations de premier plan mondial nous ont donné:



114

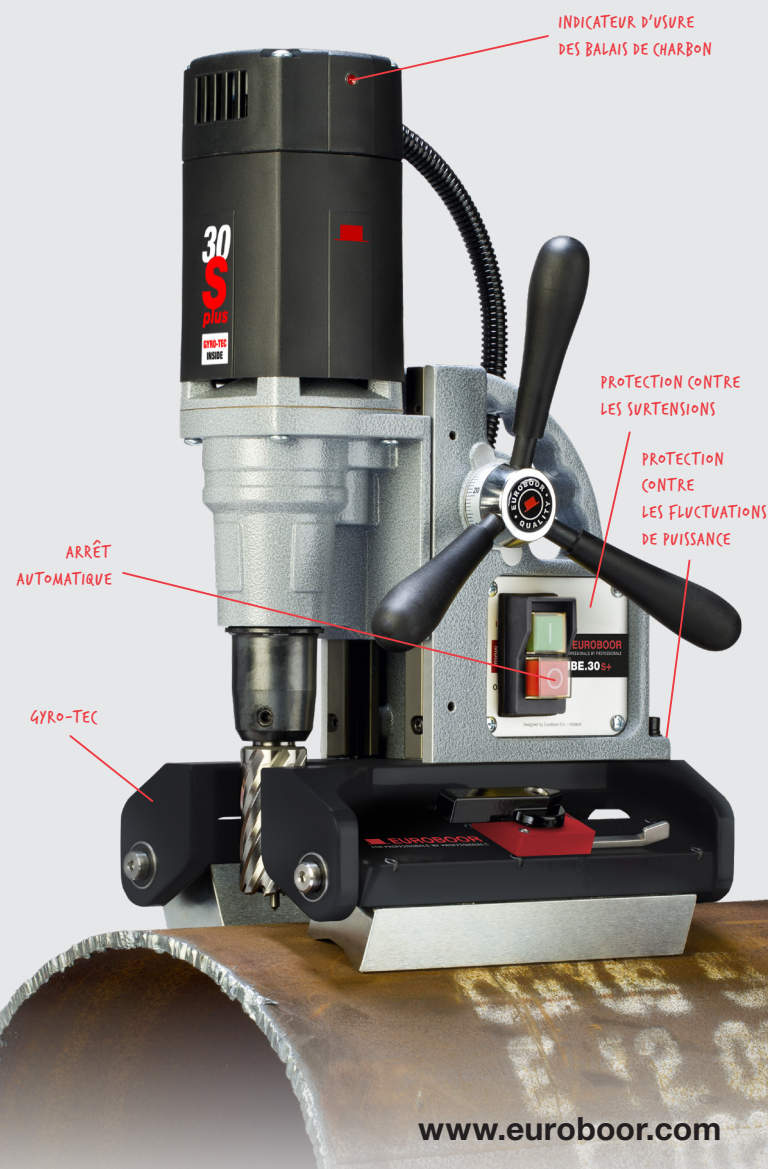
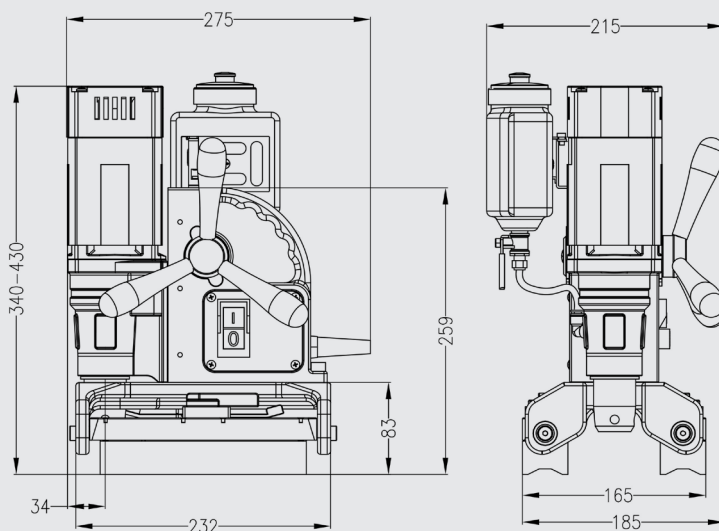

www.euroboor.com